

Features

- Low-profile design
- Powerful neodymium motor
- High 25W power handling
- Large square mounting plate
- High-force 32mm voice coil
- Mounts via adhesive or screws

Parameters

Impedance (Ω)	8
Re (Ω)	6.9
Le (mH) @ 1 kHz	0.55
Fs (Hz)	63
Qms	
Qes	
Qts	
Mms (g)	12.6
Cms (mm/N)	
Sd (cm ²)	
Vd (cm ³)	
BL (Tm)	
VAS (liters)	
XMAX (mm)	0.8
VC Diameter (mm)	32
Net Weight (kg)	0.12
RMS Power Handling (w)	25
Usable Frequency Range (Hz)	60 - 12,000

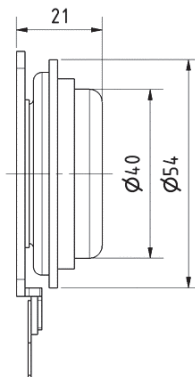
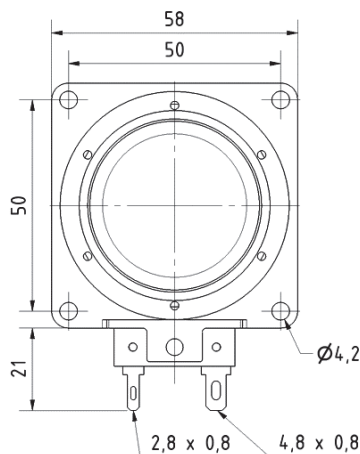

Note: All dimensions in mm.

Frequency Response

N/A

Impedance/Phase

N/A